

# BILL OF MATERIAL

ITEM	QTY	PN	DESCRIPTION	MATERIAL
1	1	99000017	BODY, MACH, 2", FP, YEL	MDPE, PE2708, YEL
2	2	99000023	RETAINER, MOLD, 2" FP	POLYPROPYLENE, N02G00
3	2	99000529	END, MACH, 2", FP, YEL, DR11	MDPE, PE2708, YEL
4	2	99000716	SEAT-SEAL, 2", FP, BUNA N60-LT	BUNA-N, 60 D, N60-LT
5	1	99000038	STEM, MACH, 2", FP	ACETAL, COPOLYMER, NATURAL
6	1	99000028	ACTUATOR, MACH, 2", FP, WHITE	POLYPROPYLENE, N02G00
7	1	99000941	O-RING, #139, 70D, BUNA, 2.18X.103	BUNA-N, 70 DUROMETER
8	2	99000027	O-RING, #119, 70D, BUNA, 0.92X.103	BUNA-N, 70 DUROMETER
9	1	99000021	BALL, MACH, 2", FP	POLYPROPYLENE, N02G00
10	1	99000195	LABEL, NAMETAG, PB GAS	POLYESTER W/ ACRYLIC ADHESIVE
11	4	99000404	LABEL, TTR, 2.0X1.0, 1" CORE	POLYESTER W/ ACRYLIC ADHESIVE

TOLERANCES UNLESS OTHERWISE NOTED

.XX ± .015  
.XXX ± .005  
ANGLES ± 1°  
MACH. FINISH

This print is the property of Kerotest Manufacturing Corp. and is not to be used in any way directly or indirectly detrimental to our interest. It is submitted under a confidential relationship for a specific purpose, and the recipient agrees by accepting this drawing not to supply or disclose any information regarding it to any unauthorized person.

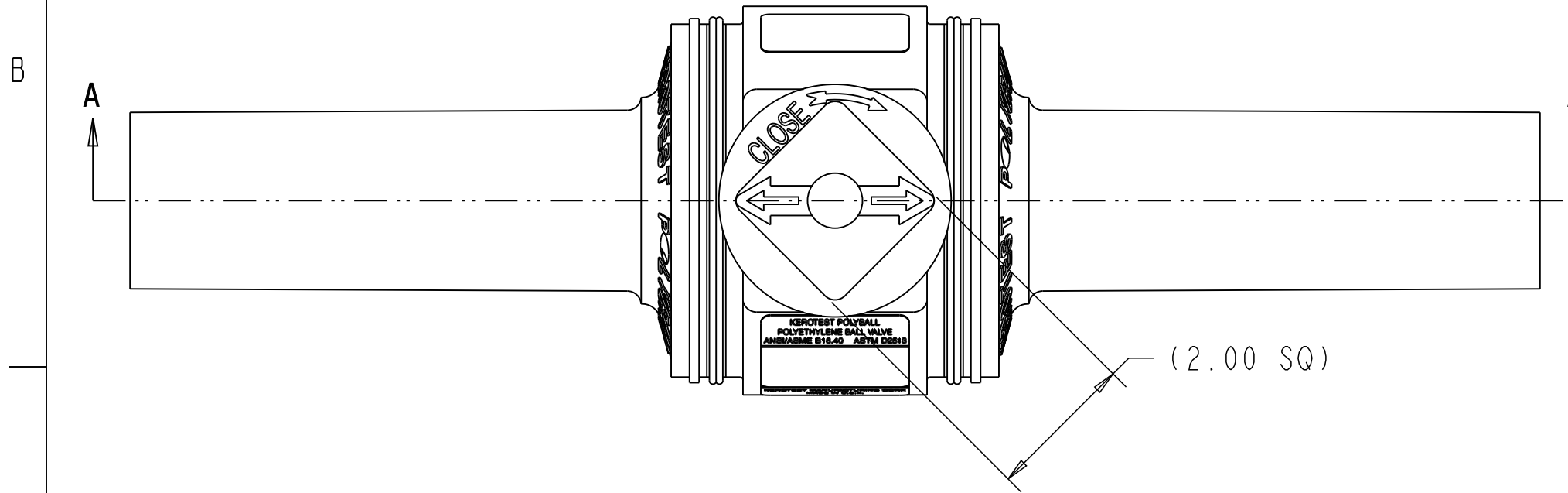
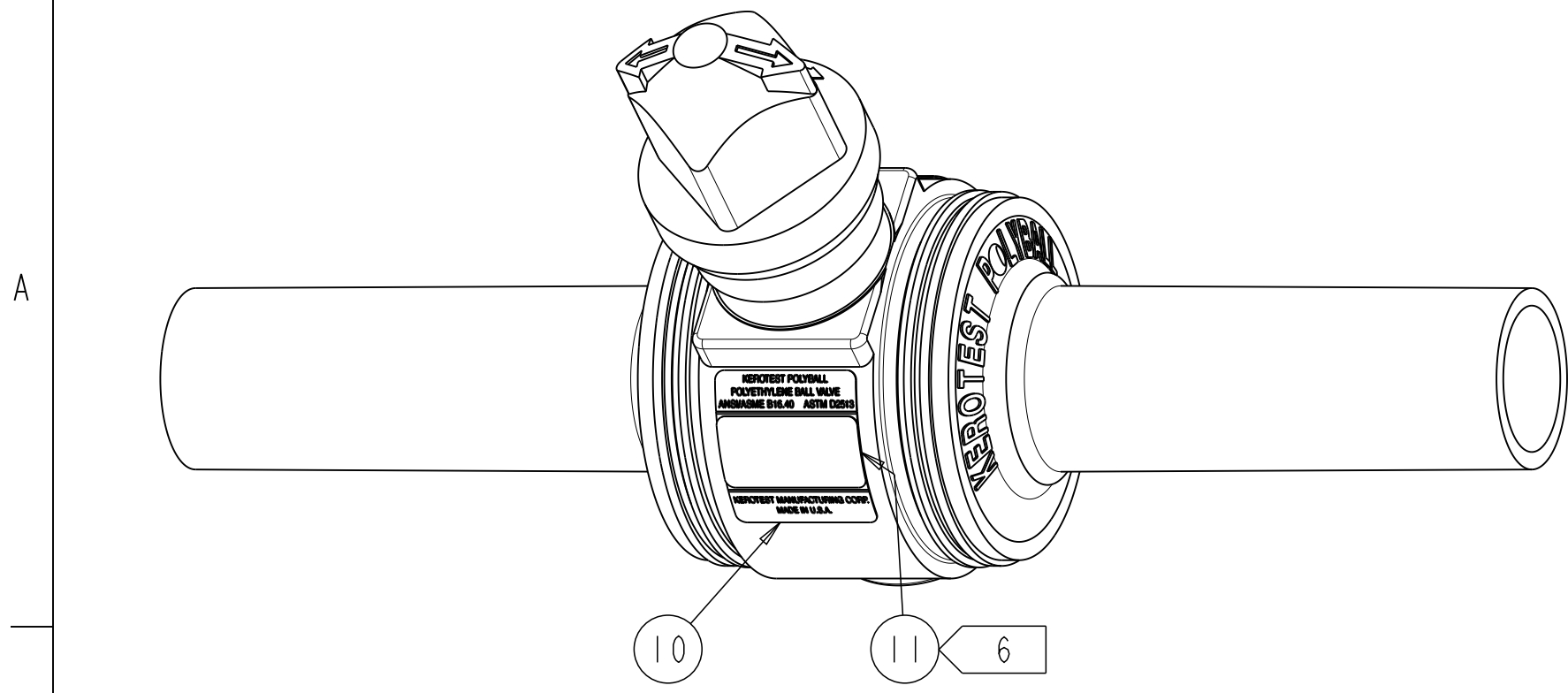

## NOTES:

- DESCRIPTION: FULL PORT, 1/4 TURN, 2" IPS, DR11 POLYBALL GAS VALVE
- TEMP RANGE: -20°F TO 140°F
- ASME B16.40 AND ASTM D2513 COMPLIANT
- APPROXIMATE WEIGHT: 4.2 Lbs
- VALVE COLOR:  
BODY: YELLOW  
ACTUATOR: WHITE
- PRINT TAG ACCORDING TO ASSEMBLY PROCEDURE  
2 LABELS APPLIED TO ASSEMBLY  
2 LABELS APPLIED TO SHIPPING CARTON

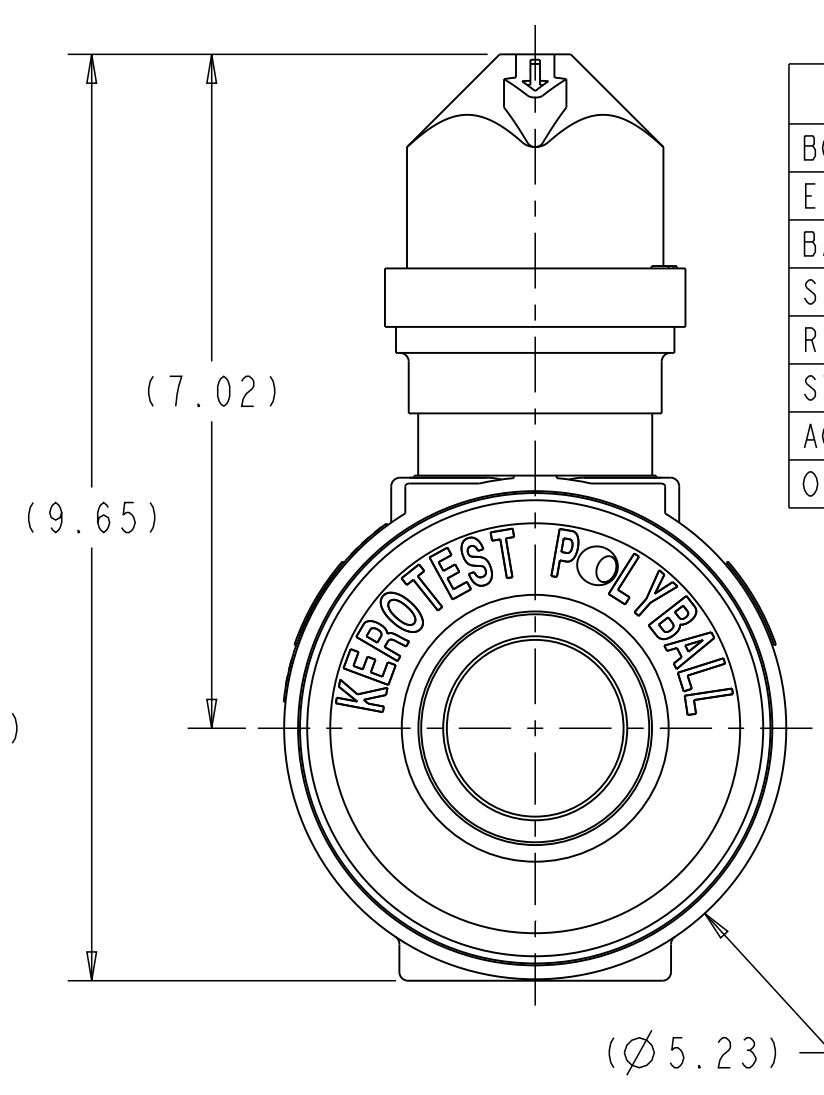
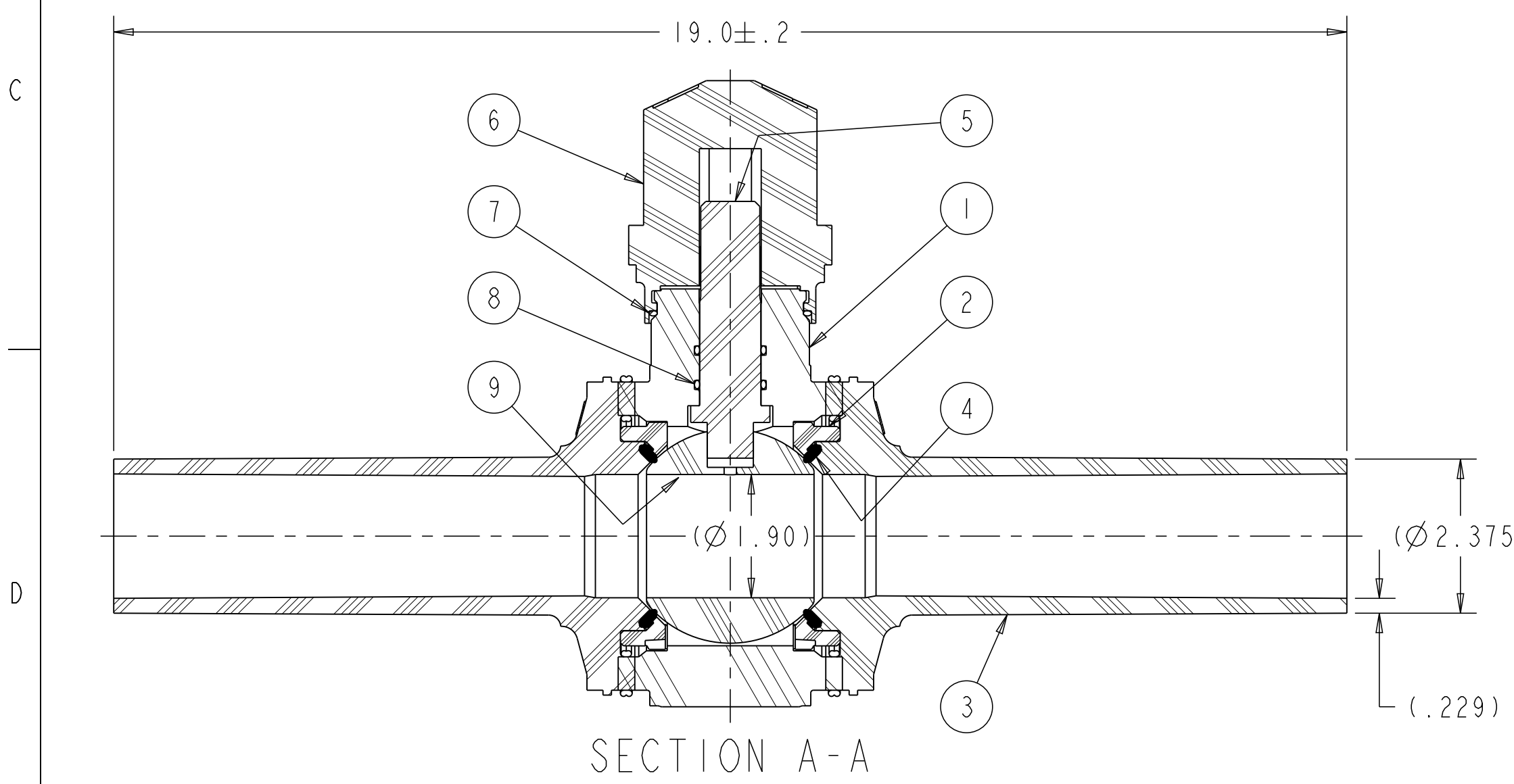

VALVE MATERIALS	
BODY	PE2708
ENDS	PE2708
BALL	POLYPROPYLENE
SEAT SEALS	BUNA-N
RETAINERS	POLYPROPYLENE
STEM	ACETAL
ACTUATOR	POLYPROPYLENE
O-RINGS	BUNA-N

INITIAL RELEASE  
EAN: S-1147  
**A** 01-18-2016  
REVISIONS

**KPB-BALL-VLV, 2"YEL,FP,S11**  
COPYRIGHT KEROTEST © ALL RIGHTS RESERVED

DRAWN/DATE BMS 01-18-2016	<b>KEROTEST</b> PITTSBURGH, PA. DRAWING NUMBER <b>99042011</b>
ENG APPROVED	
MFG ENG APPROVED / CHECKED	
O.A. APPROVED	

SCALE: 0.50 SHEET SIZE: C SHEET: 1 OF 1